

Video Security



VKC-1413/W2

1/4" Colour Camera with 2.6-5.6mm Lens
VHP-2 Housing, 380TVL

Art-No. 96044



Features

Color Brd. Camera VKC-1413 in Weatherproof Housing
1/4" CCD Sensor Chip
Resolution of 380 Horizontal Lines
Electronic Shutter Control (ESC)
High Sensitivity

Integrated Lens: F2.0/2.6-5.6mm
Supply Voltage: 12 VDC
Compact Version
Index of Protection: IP67
Protected Pan and Tilt Fixing Mechanism

Specifications

Application range	security
System	Colour, CCIR/PAL
Video standard	PAL
Sensor size	1/4"
Imager	Sony Super HAD Interline Transfer CCD, CCD
Active picture elements	Approx. 290,000 (H) 500 x (V) 582
Synchronization	Internal
Gamma correction	approx. 0.45
Sensitivity (at 50% video signal)	0,5Lux, at F1.2 (VT measurement result), 1.4Lux at F2.0
Electronic shutter control (ESC)	1/50 ~ 1/100,000sec.
Integration rate	no
Backlight compensation	no
Aperture Correction (APC)	Yes (horizontal)
IR cut filter	no
Video outputs (type)	CVBS
Video outputs	1Vp-p, CVBS, 75ohms
Lens type	varifocal
Lens	F2.0~2.7 / 2.6~5.6mm (fixed iris)
Lens mount	integrated lens

VKC-1413/W2

(Specifications continued)

Mount	n/a
Nominal format size	1/3"
Aspherical technology	no
Focal length	2,6-5,6mm
Horizontal angle of view	69-35°
Iris control	no
Serial interfaces	no
Cable connection	Wiring for video and voltage supply made, accessible from outside
Protection rating	IP67
Supply voltage	12VDC, (+/-10%)
Power consumption	approx. 1.5watts
Temperature range (Operation)	-30°C ~ +40°C
Housing material	aluminium
Housing	outdoor housing, Aluminium w. glass front screen
Integrated wall mount	yes
Hidden cable management	yes
Heater/sunshield	No
Sunshield	no
Window heater	no
Clear Shield	no
Colour (housing)	anodized light (C-0)
Dimensions (HxWxD)	See drawing
Weight	480g
Parts supplied	Bag of screws

Accessories

70448 / VT-PS12DC-6	Plug-in Power Supply Unit 100-240VAC 12VDC (1.0Amp), Regulated, w. open Ends
----------------------------	--

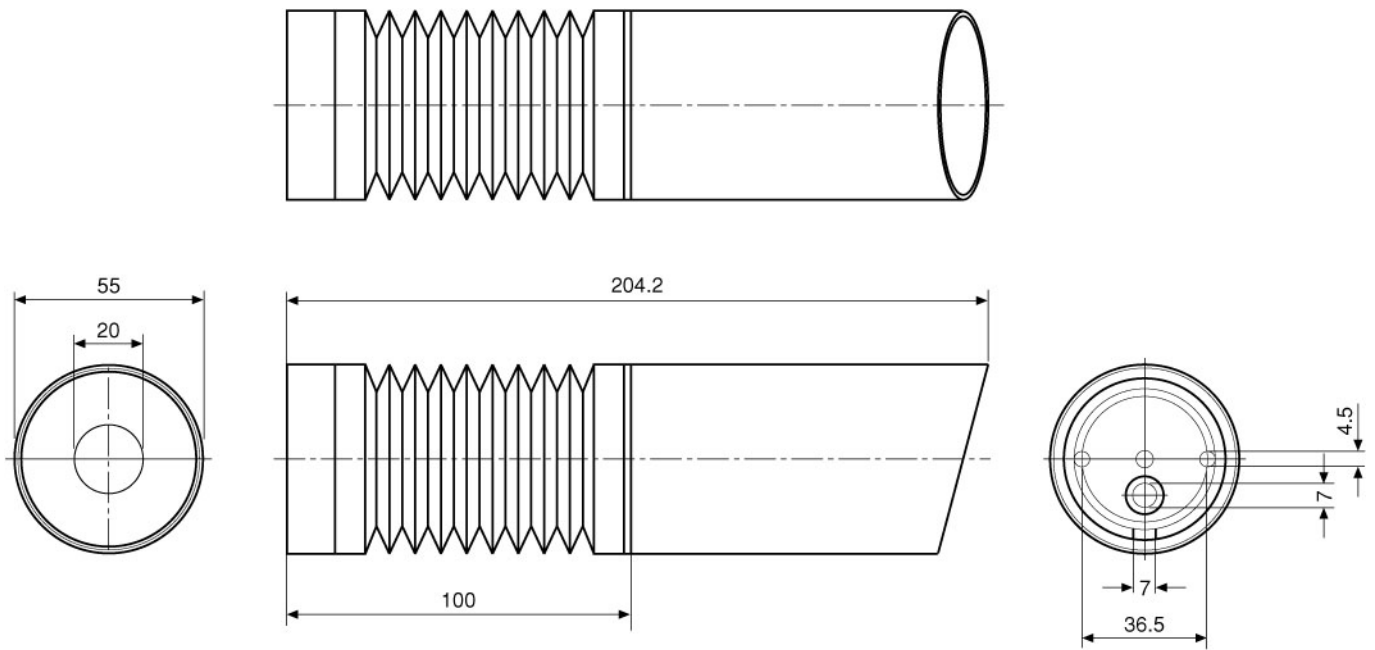

Maße/Dimensions: mm

Sicherheitssysteme Uebachs GmbH
 Your Contact: Fridtjof Uebachs
 Königsallee 22 · 40212 Düsseldorf
 Phone 0211-210744-0 · Fax 0211-210744-29
 technik@uebachs.de · www.uebachs.de

