

Video Security



CANDID C-02

1/3" Colour Camera with F1.0/3-8mm Lens
Candid Dustproof Housing, 480TVL

Art-No. 96002



Features

Colour Camera in Dustproof Housing
Resolution of 480 Horizontal Lines
Digital Signal Processing (DSP)
Back Light Compensation (BLC)
Electronic Shutter Control (ESC)

Integrated Eclipser Function
Horizontal and Vertical Aperture correction (APC)
High Sensitivity
Lens: F1.0/3-8mm
Index of Protection: IP54

Specifications

Application range	security
System	Colour
Video standard	PAL
Signal processing	Digital (DSP)
Sensor size	1/3"
Imager	Sony Super HAD Interline Transfer CCD, CCD
Active picture elements	approx. 440,000, 752(H) x 582(V)
Synchronization	Internal
Gamma correction	approx. 0.6
Sensitivity (at 50% video signal)	0,7Lux, at F1.2; 0.7Lux at F1.0
Electronic shutter control (ESC)	1/50 ~ 1/15,000sec.
Integration rate	no
Backlight compensation	BLC, ON/OFF switchable
IR cut filter	no
Video outputs (type)	CVBS
Video outputs	1Vp-p, CVBS, 75ohms
Lens type	varifocal
Lens	F1.0/3-8 mm with manual control
Lens mount	integrated lens

CANDID C-02

(Specifications continued)

Mount	CS
Nominal format size	1/3"
Aspherical technology	yes
Focal length	3-8mm
Horizontal angle of view	91-36°
Iris control	DC
Serial interfaces	no
Operations	AGC, BLC, Eclipser ON/OFF, Level for DC controlled lenses
Cable connection	Wiring for video and voltage supply made, accessible from outside
Protection rating	IP54
Supply voltage	12VDC, (+/-10%)
Power consumption	3watts
Temperature range (Operation)	0 ~ +40°C
Housing material	aluminium
Housing	outdoor housing, Aluminium w. plastic front and back
Integrated wall mount	yes
Hidden cable management	yes
Sunshield	yes
Window heater	no
Clear Shield	no
Colour (housing)	RAL9016
Colour	RAL9016 (Body and sunshield), RAL7035 (Front and back), RAL7037 (Inner ball, fixing ring)
Dimensions (HxWxD)	See drawing
Weight	1.2kg
Parts supplied	3mm Allen key, Bag of fixing screws

Accessories

79494 / VHU-NT1

Power Supply Unit for Candid Housing Series
230VAC/12VDC-14VAC(Camera/Heater)

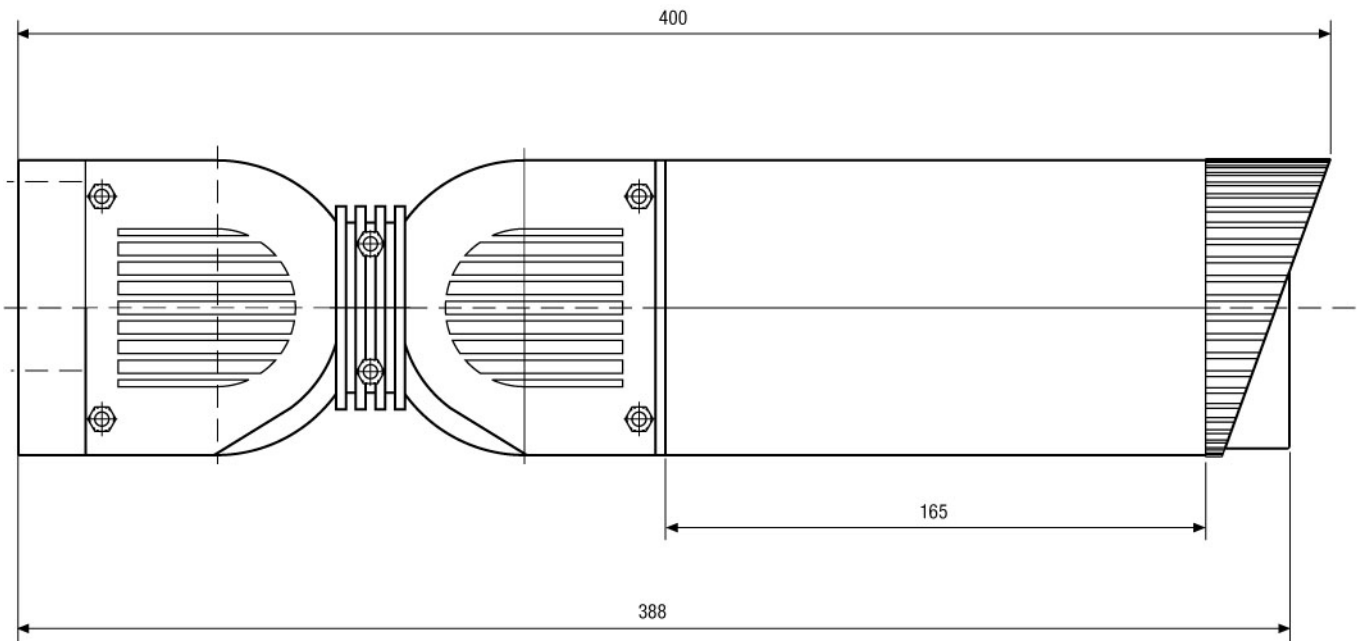
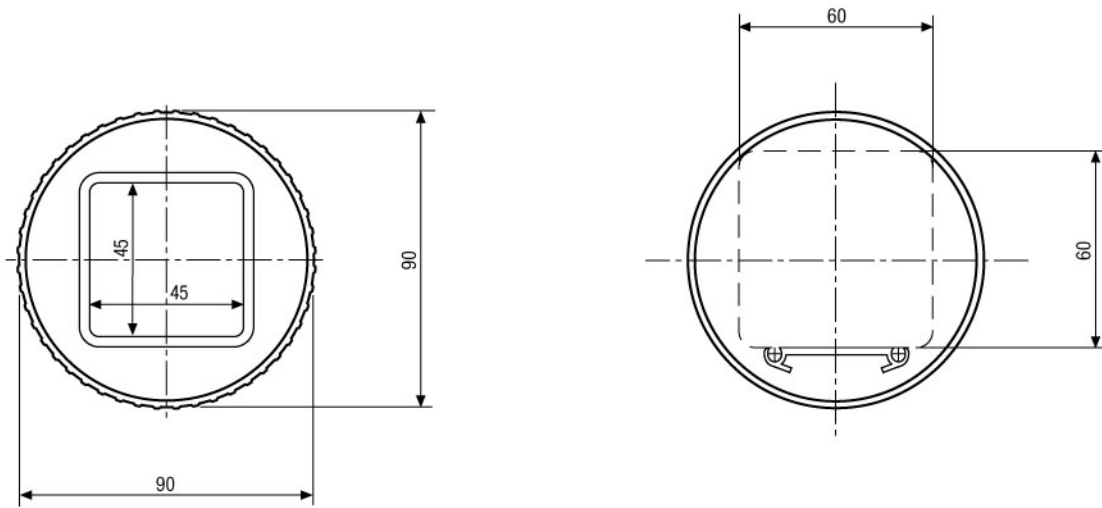

Maße/Dimensions: mm

Sicherheitssysteme Uebachs GmbH
 Your Contact: Fridtjof Uebachs
 Königsallee 22 · 40212 Düsseldorf
 Phone 0211-210744-0 · Fax 0211-210744-29
 technik@uebachs.de · www.uebachs.de

