

Video Security



VKC-1310S/230V
1/3" Colour Camera
DSP, 230VAC, 330TVL
Art-No. 91934



Lens is not included with the camera

Features

Resolution of 330 Horizontal Lines
High Sensitivity
Digital Signal Processing (DSP)
Automatic Gain Control (AGC)
Linear Shutter Control (ESC)
Automatic Shutter Control (AES)

Aperture Control (APC)
Backlight Compensation (BLC)
Internal Synchronization
Auto Iris and DC Iris Control
C/CS Mount
Supply Voltage: 230VAC

Specifications

Video standard	CCIR/PAL
System	Colour
Sensor size	1/3"
Imager	CCD, Sony Super HAD Interline Transfer CCD
Active picture elements	approx. 290,000, 500(H) x 582(V)
Signal processing	Digital (DSP)
Synchronization	Internal/AC line lock
Signal-to-noise ratio	50dB (AGC OFF)
Gamma correction	0.45 (ON/OFF switchable)
Sensitivity (at 50% video signal)	0,45Lux, at F1.2 (VT measurement result)
Electronic shutter control (ESC)	1/50 ~ 1/10,000sec.
Integration rate	no
Automatic gain control (AGC)	On/Off switchable
Backlight compensation	BLC
White balance (AWB)	ON/OFF switchable
Flickerless function	On/Off switchable
IR cut filter	no
Lens mount	C/CS

VKC-1310S/230V

(Specifications continued)

Usable iris controls	Manual iris, Auto-Iris/DC controlled iris
Auto-Iris voltage supply	9VDC (40mA max.)
External adjustments	AGC, BLC, ESC, Flickerless, AWB ON/OFF, AI/DC iris control, AES/ESC, Flange focus Level for DC controlled lenses, V-phase adjustment
Video outputs (type)	CVBS
Video outputs	1Vp-p, composite, 75ohms, BNC
External connections	Video (BNC), Auto-Iris/DC iris (4-pin), Power cord
Serial interfaces	no
Camera mount	1/4" - 20 UNC thread on top and bottom
Supply voltage	230VAC
Power consumption	approx. 7watts
Temperature range (Operation)	-10° ~ +50°C
Dimensions (HxWxD)	See drawing
Colour	Body: Pantone 877, Front and back: Pantone 8400C
Weight	600g
Parts supplied	Camera, C/CS Mount ring, 4-pin lens plug, Manual

Accessories

70771 / WD-23	Wall Mount Bracket with Ball Joint, 1/4" Camera Fixing Screw, Pantone 877
70769 / WD-22	Wall Mount Bracket with Ball Joint, 1/4" Camera Fixing Screw, Beige Grey
70688 / WD-18	Wall Mount with Ball Joint, 1/4" Camera Fixing Screw, Beige Grey

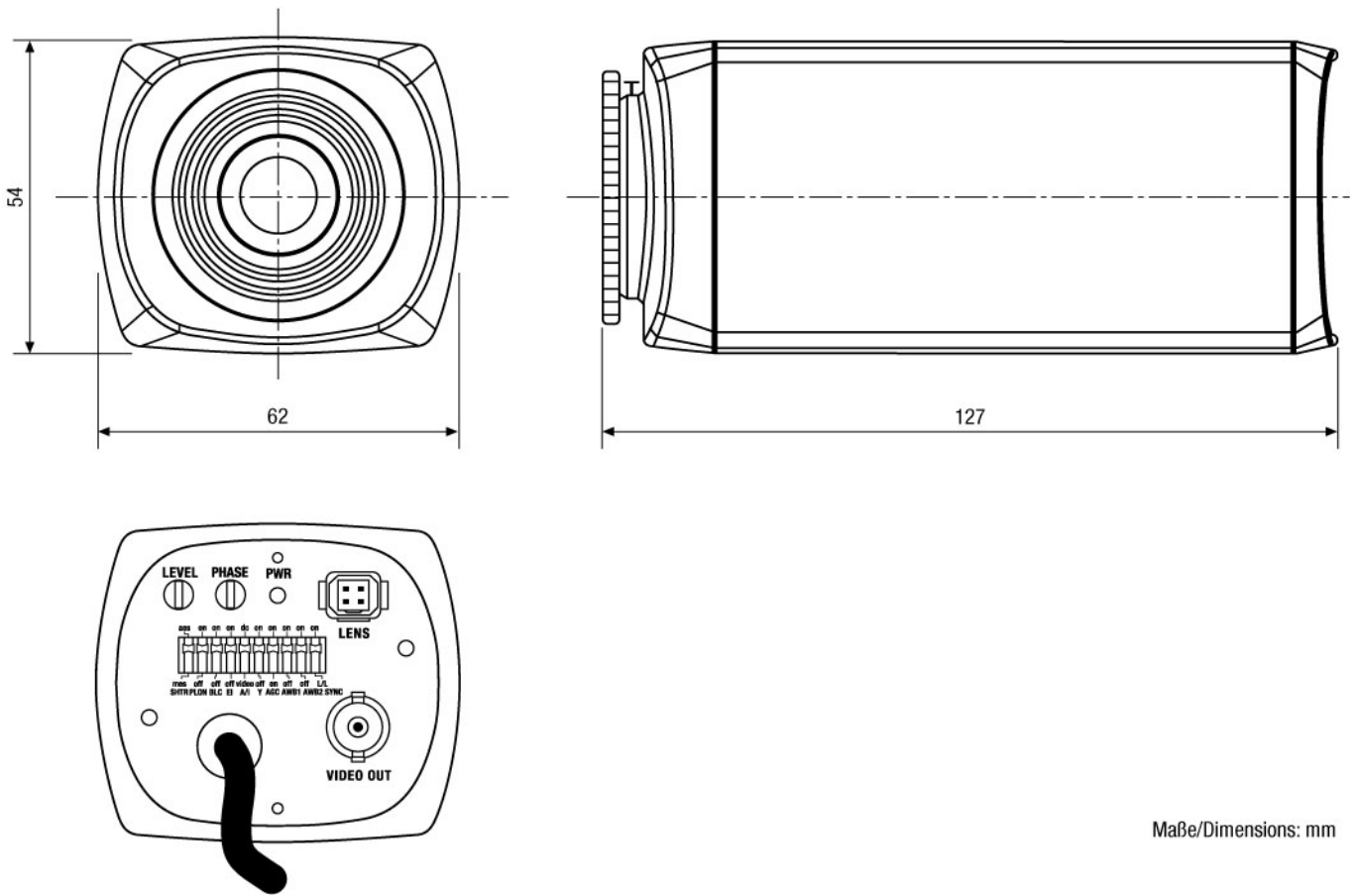

Maße/Dimensions: mm

Sicherheitssysteme Uebachs GmbH
 Your Contact: Fridtjof Uebachs
 Königsallee 22 · 40212 Düsseldorf
 Phone 0211-210744-0 · Fax 0211-210744-29
 technik@uebachs.de · www.uebachs.de

